

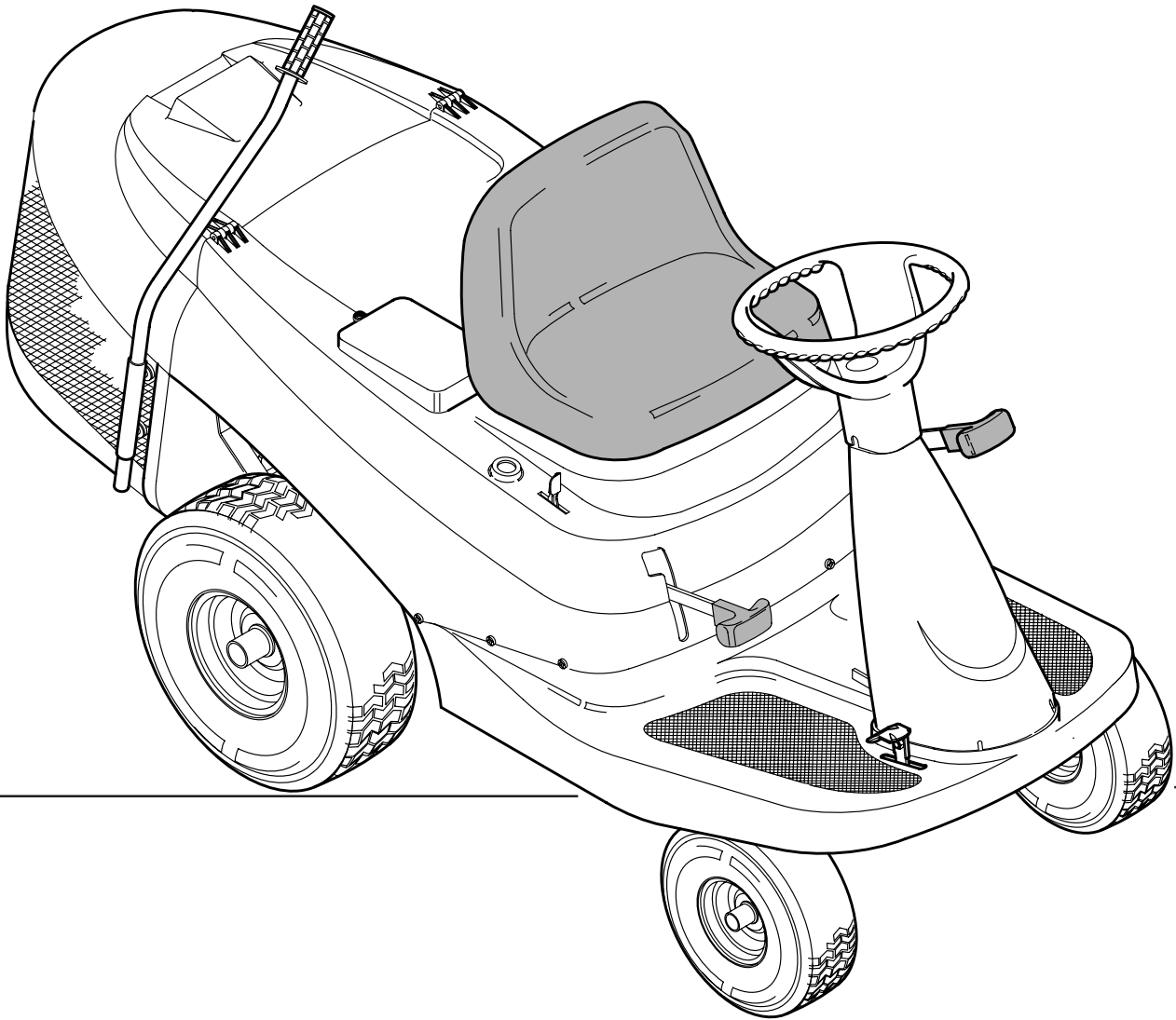

HYDROSTAR mod.67 HYDROMAX mod.76

**TAV.1**

Kit motore	Kit moteur	Motor kit	Kit motor	Kit motor
Kit motor	Kit motor	Kit silnik	Kit motor	Kit motor

TAV.2

Kit cambio	Kit transmission	Gear kit	Getriebe kit	Kit cambio
Kit versnelling	Kit câmbio	Kit bieg	Kit váltokar	Kit převodovka

TAV.3

Kit piatto	Kit plateau	Kit plate	Kit Teller	Kit plato
Kit bord	Kit prato	Kit talerz	Kit tanyer	Kit disk

TAV.4

Kit telaio	Kit châssis	Kit chassis	Kit Rahmen	Kit chasis
Kit frame	Kit chassi	Kit korpus	Kit váz	Kit kostra

TAV.5

Kit sterzo	Kit org.direction	Steering kit	Kit Steuer	Kit dirección
Kit stuur	Kit direção	Kit ramie	Kit kormany	kit volante

TAV.6

Kit comandi	Kit commande	Control kit	Auftrag kit	Kit mando
Kit hendel	Kit alavanca	Kit dźwignia	Kit emelo	Kit paka

TAV.7

Kit imp.elettrico	Kit electrique	Electric kit	Kit Elektro	Kit electrico
Kit elektrisch	Kit electrica	Kit elektryczny	Kit elektromos	Kit elektrichy

TAV.8

Kit raccogliërba	Kit bac	Grass catcher kit	Grasfangkorbes kit	Kit cestillo
Kit cesto	Kit zbiornika na trawę	Felszerelés kit	Zberaca skosenej travy kit	Kit kostra

mod. 67 MEC - TAV.1

KIT MOTORE - KIT MOTEUR - MOTOR KIT - KIT MOTOR - KIT MOTOR - KIT MOTOR - KIT MOTOR - KIT SILNIK - KIT MOTOR - KIT MOTOR

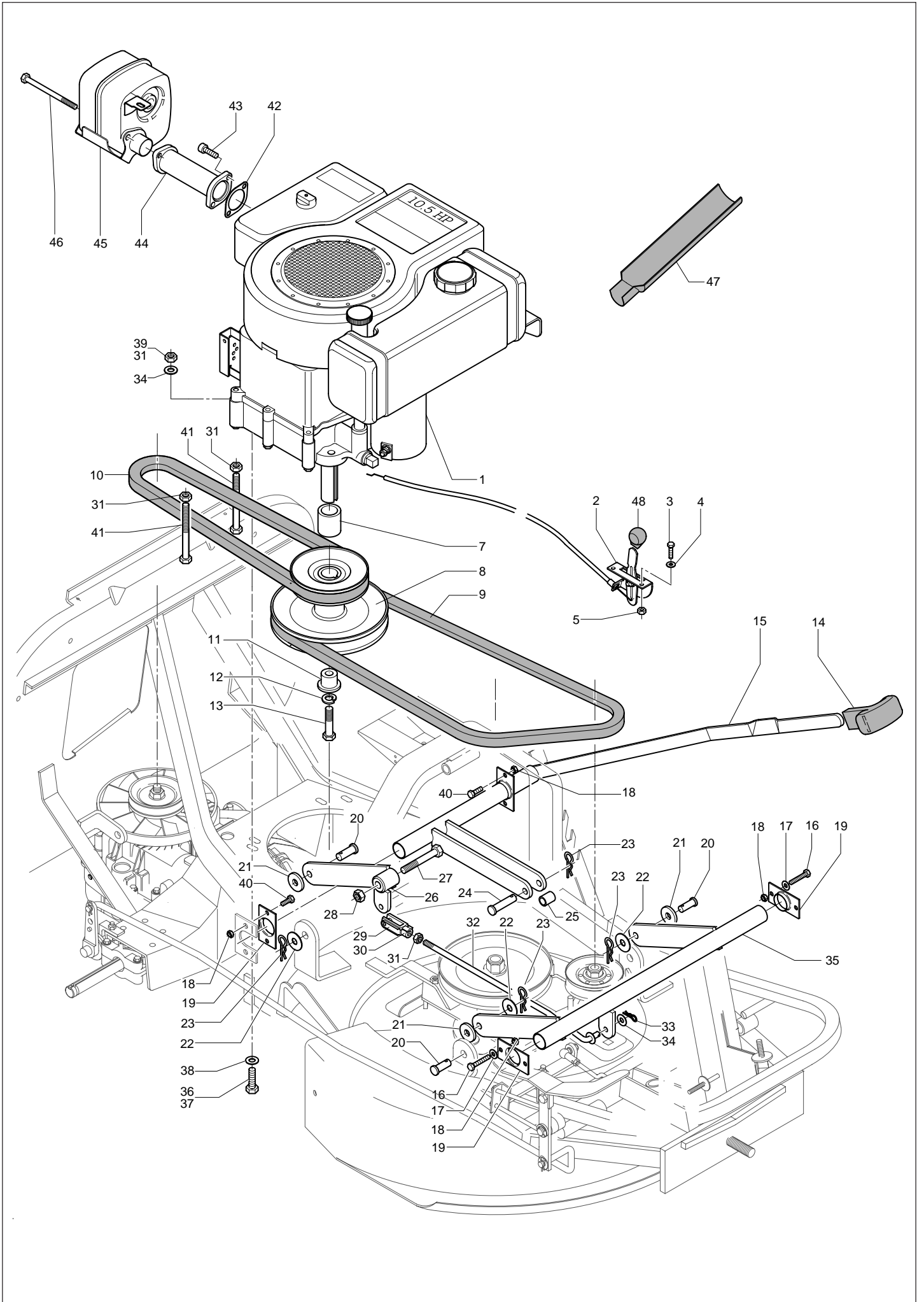

mod. 67 MEC - TAV.1

KIT MOTORE - KIT MOTEUR - MOTOR KIT - KIT MOTOR - KIT MOTOR - KIT MOTOR - KIT MOTOR - KIT MOTOR - KIT MOTOR - KIT MOTOR

N.ord. - N. pieces part. N. - Bestell N.	RICAMBI SPARE PARTS	RECHANGES ERSATZTEILE	RECAMBIOS ONDERDELEN	SOBRESSALENTES CZĘŚCI ZAMIENNE	CȘEREALKATRÉSZEK NÁHRADNÉ SÚCIÁSTKY	Q	
1 BS 28B7 07	motore motor	moteur Motor	motor motor	motor silnik	motor motor	1	B&S 10,5HP I/CA.E.
1 TECNA T10	motore motor	moteur Motor	motor motor	motor silnik	motor motor	1	TECUMSEH TVM 220
2 10 3034 30	acceleratore completo accelerator	accélérateur Gashebel	acelerador gashendel	acelerador gazu	elemő rychlostná	1	
3 10 8303 00	vite screw	vis Schraube	tornillo schroef	parafuso sruba	csavar skrutka	2	TE M5x16
4 10 8050 00	rosetta piana washer	rondelle Scheibe	arandela borgring	aniha podkladka	alátét podlozka	2	Ø 5x10x1 ZB
5 20 2821 00	dado autobloccante nut	ecrou Mutter	tuerca moer	porca nakrętk	anya matica	2	M5-H7 UNI 7473-ZB
7 10 3033 70	distanziale superiore upper spacer	entretoise supérieure Oberes Distanzstück	distanciador superior bonveste afstandstuk	separador superior przekładka górna	felső távítító horní rozperka	1	Ø 25,5x35x28 H
8 10 3300 30/A	puleggia motore pulley	poulie Riemenscheibe	polea motor poelie	polie do motor kółko zamachowe	tárcsa remenica motora	1	
9 10 3015 00	cinghia belt	courroie Keilriemen	corroie riem	correia pasel napędowy	ékszj remen	1	SPA 1180
10 10 3301 30	cinghia belt	courroie Keilriemen	corroie riem	correia pasel napędowy	ékszj remen	1	X13-850LP
11 10 3019 00	distanziale inferiore lower spacer	entretoise inférieure Unteres Distanzstück	distanciador inferior anderste afstandstuk	separador inferior przekładka dolna	alsó távítító dolní rozperka	1	Ø 12x25,3x23,5 H
12 10 3019 20	rosetta elastica washer	rondelle Scheibe	arandela borgring	aniha podkladka	alátét podlozka	1	Ø 12 RINF. UNI 9195
13 10 3019 10	vite screw	vis Schraube	tornillo schroef	parafuso sruba	csavar skrutka	1	TE 7/16" UNF x 2"
14 10 3302 53	manopola nera block knob	poignée noire Schwarzer Griff	manopla negra zwarte knop	botão preto uchwyt czarny	fekete húzókar cerná rukojeť	1	
15 10 3006 50	leva compl.solleval.lama cutter lift complete lever	levier compl.soulev.lame Kompl. Messerhebel	palanca compl.lev.cuchilla hendel opheffing mes	alavanca compl.lev.lamina dźwignia podnoszenia ostrza	komp.pengeemelőemeltű komp.páka zdvihnúti nože	1	
16 10 5010 00	vite screw	vis Schraube	tornillo schroef	parafuso sruba	csavar skrutka	4	TE M6x35 UNI 5737-8,8 Z.
17 10 1260 00	rosetta piana washer	rondelle Scheibe	arandela borgring	aniha podkladka	alátét podlozka	3	Ø 6x18x1,5
18 20 2818 00	dado autobloccante nut	ecrou Mutter	tuerca moer	porca nakrętk	anya matica	8	M6 - H8 UNI 7473 Z.
19 10 3006 80	supporto cerniera hinge support	support charnière Scharnierhalter	soporte cremallera scharnier support	suporte dobradiça oparcie zawiasy	csuklóspántartó držák závesu	3	
20 10 3027 20	perno sollevam.piatto plate lift pin	pivot soulèvem.plateau Tellerhebezapfen	perno levantam.plato pen voor opheffing bord	perno levantam.prato sworzen podnoszenia	tányéremelőtengely cep zdvihnúti dčku	3	Ø 10x29
21 10 3011 70	rondella in nylon washer	rondelle Scheibe	arandela borgring	aniha podkladka	alátét podlozka	3	Ø 10x30x3
22 20 1130 00	rosetta piana washer	rondelle Scheibe	arandela borgring	aniha podkladka	alátét podlozka	3	Ø 10x30x2,5
23 10 3027 60	coppiglia elastica centr. central elastic split pin	goupille élastique centr. Mittlerer Gummisplint	clavija elástica central centr.elastische splitpen	pino elástico central zawlecška elast.cent.	csavaranyabiztosítás pruziná závlacka sredná	4	Ø 2,5x50
24 10 3027 10	perno sollevam.piatto plate lift pin	pivot soulèvem.plateau Tellerhebezapfen	perno levantam.plato pen voor opheffing bord	perno levantam.prato sworzen podnoszenia	tányéremelőtengely cep zdvihnúti dčku	1	Ø 10x45
25 10 3022 40	boccola bushing	douille Buchse	casquillo huls	casquillo tuleja	csapágycsésze pouzdro	1	Ø 11x14x19 H Z
26 10 3011 50	leveraggio posteriore rear leverage	leviers arrières Hinteres Hebelwerk	palancas posterior achterste hendel	palanca traseira układ dźwigni tylny	hátsó emeltűrendszer zasní pákovy mechanismus	1	
27 10 3008 30	vite screw	vis Schraube	tornillo schroef	parafuso sruba	csavar skrutka	1	TSPEI M10x70 UNI 5933-8,8 Z
28 10 5011 60	dado autobloccante nut	ecrou Mutter	tuerca moer	porca nakrętk	anya matica	1	M10-H12 UNI 7473 Z.
29 10 3010 20	snodo kalvas kalvas joint	articulation kalvas Kalvas-Gelenk	articulación kalvas kalvas geleding	articulação kalvas przegub kalvas	kalvas csukló klóub pro kalvas	1	M8x32 UNI 1676 L=58
30 10 3012 20	clips per kalvas clips for kalvas	clips pour kalvas Kalvas-Klips	clips para kalvas klemmen voor kalvas	grampos para kalvas zaciski do kalvas	kalvas kapocs spona pro kalvas	1	M8 TIPO LUNGO
31 20 1063 00	dado nut	ecrou Mutter	tuerca moer	porca nakrętk	anya matica	2	M8 UNI 5587
32 10 3010 00	tirante sollevam.piatto plate lift tie rod	tirant soulèvem.plateau Tellerhebestange	tirante levantam.plato trekstang voor oph.bord	extensor levant.prato ciągno podnoszenia	tányéremelő tartórúd tárho zdvihnúti disku	1	
33 10 2814 00	coppiglia elastica elastic split pin	goupille élastique Gummisplint	clavija elástica elasatische splitpen	pino elástico zawlecška elastycsna	csavaranyabiztosítás pruzná závlacka	1	Ø 1,8x33
34 10 1142 00	rosetta piana washer	rondelle Scheibe	arandela borgring	aniha podkladka	alátét podlozka	5	Ø 8x16x1,5 Z.
35 10 3012 00	leveraggio anteriore front leverage	leviers avant Vorderes Hebelwerk	palancas anterior voorste hendel	palanca dianteira układ dźwigni przedni	első emeltűrendszer přední pákovy mechaniz.	1	
36 10 1217 00	vite screw	vis Schraube	tornillo schroef	parafuso sruba	csavar skrutka	3	TE M8x35 UNI 5737-8,8 Z.
37 10 0691 00	vite screw	vis Schraube	tornillo schroef	parafuso sruba	csavar skrutka	1	TE M8x45 UNI 5739 -8,8 Z.
38 10 0663 00	rosetta piana washer	rondelle Scheibe	arandela borgring	aniha podkladka	alátét podlozka	4	Ø 8x24x2
39 20 4049 00	dado autobloccante nut	ecrou Mutter	tuerca moer	porca nakrętk	anya matica	3	M8-H10 UNI 7473
40 20 5013 70	vite screw	vis Schraube	tornillo schroef	parafuso sruba	csavar skrutka	4	TE M6x20 UNI 5739 8.8 Z.
41 30 3025 40	vite screw	vis Schraube	tornillo schroef	parafuso sruba	csavar skrutka	2	TE M8x120 UNI 5737 - Z
42 20 3032 20	guarnizione gasket	garniture Dichtung	junta pakking	garnição uszczelka	tömítés teszenie	1	B&S
42 20 3303 30	guarnizione gasket	garniture Dichtung	junta pakking	garnição uszczelka	tömítés teszenie	1	TECUMSEH
43 10 3027 30	vite screw	vis Schraube	tornillo schroef	parafuso sruba	csavar skrutka	2	TCEI 5/16" UNC x5/8"
44 20 3018 50	tubo prolunga mamitta tube	tuyau Röhre	tubo stang	tubo os	võnorúd tyc	1	B&S
44 20 3302 80	tubo prolunga mamitta tube	tuyau Röhre	tubo stang	tubo os	võnorúd tyc	1	TECUMSEH
45 20 3032 00	silenziatore/delettore/viti silencer	silensieux Schalldämpfer	silenciador silencer	silencer silencer	silencer silencer	1	B&S
45 20 3303 40	silenziatore/delettore/viti silencer	silensieux Schalldämpfer	silenciador silencer	silencer silencer	silencer silencer	1	TECUMSEH
46 20 3032 10	tirante tie rod	tirant Zugstange	tirante trekstang	tirante łącznik	võnorúd tiahlo	2	TE Ø 11x91-B&S
46 20 3303 50	tirante tie rod	tirant Zugstange	tirante trekstang	tirante łącznik	võnorúd tiahlo	2	TE Ø 11x116 TECUMSEH
47 10 3303 83	imbuto cambio olio funnel oil change	entonnoir Trichter	embudo funnel oil change	funnel oil change funnel oil change	funnel oil change funnel oil change	1	
48 10 3034 03	pomolo knob	poignée Griff	manopla knop	botão uchwyt	kuzokar rutojeť	1	

mod. 76 MEC - TAV.1

KIT MOTORE - KIT MOTEUR - MOTOR KIT - KIT MOTOR - KIT MOTOR - KIT MOTOR - KIT MOTOR - KIT SILNIK - KIT MOTOR - KIT MOTOR

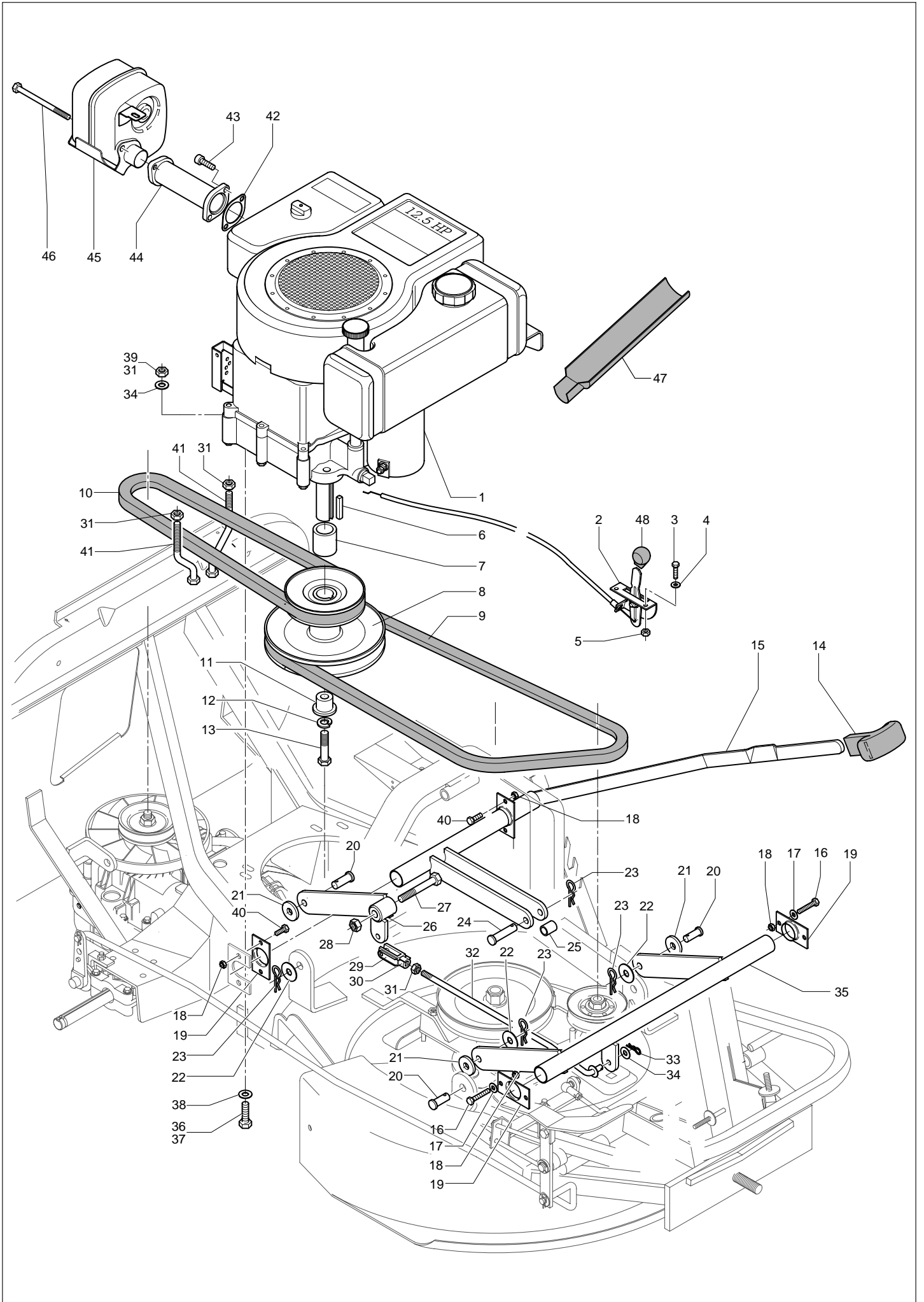

mod. 76 MEC - TAV.1

KIT MOTORE - KIT MOTEUR - MOTOR KIT - KIT MOTOR - KIT MOTOR - KIT MOTOR - KIT MOTOR - KIT MOTOR - KIT MOTOR - KIT MOTOR - KIT MOTOR

N.ord. - N. pieces part. N. - Bestell N.	RICAMBI SPARE PARTS	RECHANGES ERSATZTEILE	RECAMBIOS ONDERDELEN	SOBRESSALENTES CZĘŚCI ZAMIENNE	CȘEREALKATRÉSZEK NÁHRADNÉ SÚCIÁSTKY	Q	
1	BS 28B7 07	motore motor	moteur Motor	motor motor	motor silnik	1	B&S 12,5HP I/CA.E.
1	TECNA T10	motore motor	moteur Motor	motor motor	motor silnik	1	TECUMSEH TVM 220
2	10 3034 30	acceleratore completo accelerator	accélérateur Gashebel	acelerador gashendel	acelerador gazu	1	elemő rychlostná
3	10 8303 00	vite screw	vis Schraube	tornillo schroef	parafuso sruba	2	TE M5x16 UNI 5739-8,8 Z.
4	10 8050 00	rosetta piana washer	rondelle Scheibe	arandela borgring	aniha podkladka	2	alátét podložka Ø 5x10x1 ZB
5	20 2821 00	dado autobloccante nut	écrou Mutter	tuerca moer	porca nakrętk	2	any mática M5-H7 UNI 7473-ZB
6	10 3029 40	linguetta tab	linguette Lasche	lengueta lipje	lingueta wpust	1	nyelvecske kín 6,3x6,3x38H UNI 6604-69-A
7	10 3018 90	distanziale superiore upper spacer	entretoise supérieure Oberes Distanzstück	distanciador superior bonveste afstandstuk	separador superior przekładka górna	1	felső távolító horní rozperka Ø 25,5x35x38 H
8	10 3034 10	puleggia motore pulley	poëlie Riemenscheibe	polea motor poëlie	polie do motor kółko zamachowe	1	tárca remenica motora
9	10 3301 40	cinghia belt	courroie Keilriemen	correa riem	correia pasel napędowy	1	ékszj remen SPA 1232 LW
10	10 3301 30	cinghia belt	courroie Keilriemen	correa riem	correia pasel napędowy	1	ékszj remen X13-850LP
11	10 3019 00	distanziale inferiore lower spacer	entretoise inférieure Unteres Distanzstück	distanciador inferior anderste afstandstuk	separador inferior przekładka dolna	1	alsó távolító dolni rozperka Ø 12x25,3x23,5 H
12	10 3019 20	rosetta elastica washer	rondelle Scheibe	arandela borgring	aniha podkladka	1	alátét podložka Ø 12 RINF. UNI 9195
13	10 3019 10	vite screw	vis Schraube	tornillo schroef	parafuso sruba	1	csavar skrutka TE 7/16" UNFxF2"
14	10 3302 53	manopola nera block knob	poignée noire Schwarzer Griff	manopla negra zwarte knop	botão preto uchwyt czarny	1	fekete huzókar cerná rukojet' 19x5
15	10 3032 30	leva compl.sollever.lama cutler lift complete lever	levier compl.soulever.lame Kompl.Messerhebehebel	palanca compl.lev.uchilla hendel opheffing mes	alavanca compl.lev.lamina dźwignia podnoszenia ostrza	1	komp.pengeemeleroemelyű komp.páka zdvihnúti nože
16	10 5010 00	vite screw	vis Schraube	tornillo schroef	parafuso sruba	4	csavar skrutka TE M6x35 UNI 5737-8,8 Z.
17	10 1260 00	rosetta piana washer	rondelle Scheibe	arandela borgring	aniha podkladka	4	alátét podložka Ø 6x18x1,5
18	20 2818 00	dado autobloccante nut	écrou Mutter	tuerca moer	porca nakrętk	8	any mática M6 - H8 UNI 7473 Z.
19	10 3006 80	supporto cerniera hinge support	support charnière Scharnierhalter	soporte cremallera scharnier support	suporte dobradiça oparcje zawiasy	3	csuklóspántartó držák závesu
20	10 3027 20	perno sollevam.piatto plate lift pin	pivot soulèvem.plateau Tellerhebezapfen	perno levantam.plato pen voor opheffing bord	perno levantam.prato sworzen podnoszenia	3	tányéremelőtengely cep zdvihnúti dčku Ø 10x29
21	10 3011 70	rondella in nylon washer	rondelle Scheibe	arandela borgring	aniha podkladka	3	alátét podložka Ø 10x30x3
22	20 1130 00	rosetta piana washer	rondelle Scheibe	arandela borgring	aniha podkladka	3	alátét podložka Ø 10x30x2,5
23	10 3027 60	coppiglia elastica centr. central elastic split pin	goupille élastique centr. Mittlerer Gummisplint	clavija elástica central centr.elastische splitpen	pino elástico central zawlecska elast.cent.	4	csavaranyabiztosítás pruziná závlacka sredná Ø 2,5x50
24	10 3027 10	perno sollevam.piatto plate lift pin	pivot soulèvem.plateau Tellerhebezapfen	perno levantam.plato pen voor opheffing bord	perno levantam.prato sworzen podnoszenia	1	tányéremelőtengely cep zdvihnúti dčku Ø 10x45
25	10 3022 40	boccola bushing	douille Buchse	casquillo huls	casquillo tuleja	1	csapágycsésze pouzdro Ø 11x14x19 H Z
26	10 3011 50	leveraggio posteriore rear leverage	leviers arrières Hinteres Hebelwerk	palancas posterior achterste hendel	palanca traseira układ dźwigni tylny	1	hátsó emelőrendszer zsrni pákoy mechanizmus
27	10 3008 30	vite screw	vis Schraube	tornillo schroef	parafuso sruba	1	csavar skrutka TSPEI M10x70 UNI 5933-8,8 Z
28	10 5011 60	dado autobloccante nut	écrou Mutter	tuerca moer	porca nakrętk	1	any mática M10-H12 UNI 7473 Z.
29	10 3010 20	snodo kalvas kalvas joint	articulation kalvas Kalvas-Gelenk	articulación kalvas kalvas geleding	articulação kalvas przegub kalvas	1	kalvas csukó kloub pro kalvas M8x32 UNI 1676 L=58
30	10 3012 20	clips per kalvas clips for kalvas	clips pour kalvas Kalvas-Klips	clips para kalvas klemmen voor kalvas	grampos para kalvas zaciski do kalvas	1	kalvas kapocs spona pro kalvas M8 TIPO LUNGO
31	20 1063 00	dado nut	écrou Mutter	tuerca moer	porca nakrętk	4	any mática M8 UNI 5587
32	10 3010 00	tirante sollevam.piatto plate lift tie rod	tirant soulèvem.plateau trekslang voor oph.bord	tirante levantam.plato trekslang voor oph.bord	extensor levant.prato ciegno podnoszenia	1	tányéremelő tartórúd táhló zdvihnúti disku
33	10 2814 00	coppiglia elastica elastic split pin	goupille élastique Gummisplint	clavija elástica elasatische splitpen	pino elástico zawlecska elastycsna	1	csavaranyabiztosítás pruzná závlacka Ø 1,8x33
34	10 1142 00	rosetta piana washer	rondelle Scheibe	arandela borgring	aniha podkladka	5	alátét podložka Ø 8x16x1,5 Z.
35	10 3012 00	leveraggio anteriore front leverage	leviers avant Vorderes Hebelwerk	palancas anterior voorstel hendel	palanca dianteira układ dźwigni przedni	1	első emelőrendszer prędni pákoy mechaniz.
36	10 1217 00	vite screw	vis Schraube	tornillo schroef	parafuso sruba	3	csavar skrutka TE M8x35 UNI 5737-8,8 Z.
37	10 0691 00	vite screw	vis Schraube	tornillo schroef	parafuso sruba	1	csavar skrutka TE M8x45 UNI 5739 -8,8 Z.
38	10 0663 00	rosetta piana washer	rondelle Scheibe	arandela borgring	aniha podkladka	4	alátét podložka Ø 8x24x2
39	20 4049 00	dado autobloccante nut	écrou Mutter	tuerca moer	porca nakrętk	3	any mática M8-H10 UNI 7473
40	20 5013 70	vite screw	vis Schraube	tornillo schroef	parafuso sruba	4	csavar skrutka TE M6x20 UNI 5739 -8,8 Z.
41	10 3032 80	vite guarnizione screw	vis Schraube	tornillo schroef	parafuso sruba	2	csavar skrutka TE M8x120 UNI 5737-8,8 Z.
42	20 3032 20	guarnizione gasket	garniture Dichtung	junta pakking	garnição uszczelka	1	tömítés tesnenie B&S
42	20 3303 30	guarnizione gasket	garniture Dichtung	junta pakking	garnição uszczelka	1	tömítés tesnenie TECUMSEH
43	10 3027 30	vite screw	vis Schraube	tornillo schroef	parafuso sruba	2	csavar skrutka TCEI 5/16" UNC x5/8"
44	20 3018 50	tubo prolunga mamitta tube	tuyau Röhre	tubo stang	tubo os	1	vonórúd tyc H.118 - B&S
44	20 3302 80	tubo prolunga mamitta tube	tuyau Röhre	tubo stang	tubo os	1	vonórúd tyc TECUMSEH
45	20 3032 00	silenziatore/delettore/viti silencer	silensieux Schalldämpfer	silenciador silencer	silencer silencer	1	silencer silencer B&S
45	20 3303 40	silenziatore/delettore/viti silencer	silensieux Schalldämpfer	silenciador silencer	silencer silencer	1	silencer silencer TECUMSEH
46	20 3032 10	tirante tie rod	tirant Zugstange	tirante trekstang	tirante łącznik	2	vonórúd tiahlo TE Ø 11x91 - B&S
46	20 3303 50	tirante tie rod	tirant Zugstange	tirante trekstang	tirante łącznik	2	vonórúd tiahlo TE Ø 11x116 TECUMSEH
47	10 3303 83	imbuto cambio olio funnel oil change	entonnoir Trichter	embudo funnel oil change	funnel oil change funnel oil change	1	funnel oil change funnel oil change
48	10 3034 03	pomolo knob	poignée Griff	manopla knop	botão uchwyt	1	kuzókar rutojet'

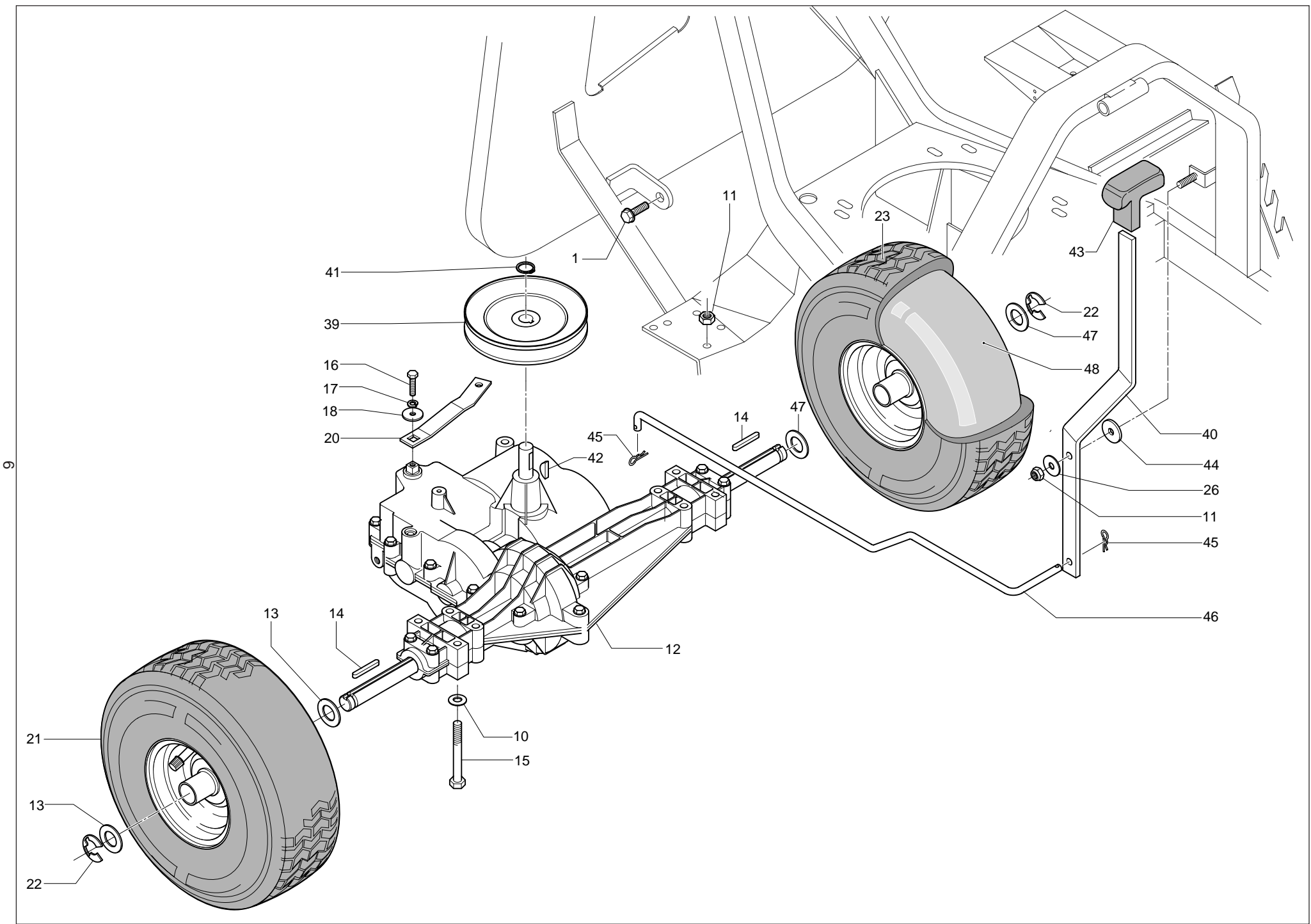

mod. 67 MEC - TAV. 3

KIT PIATTO - KIT PLATEAU - KIT PLATE - KIT TELLER - KIT PLATO - KIT BORD - KIT PRATO - KIT TALERZ - KIT TANYER - KIT DISK

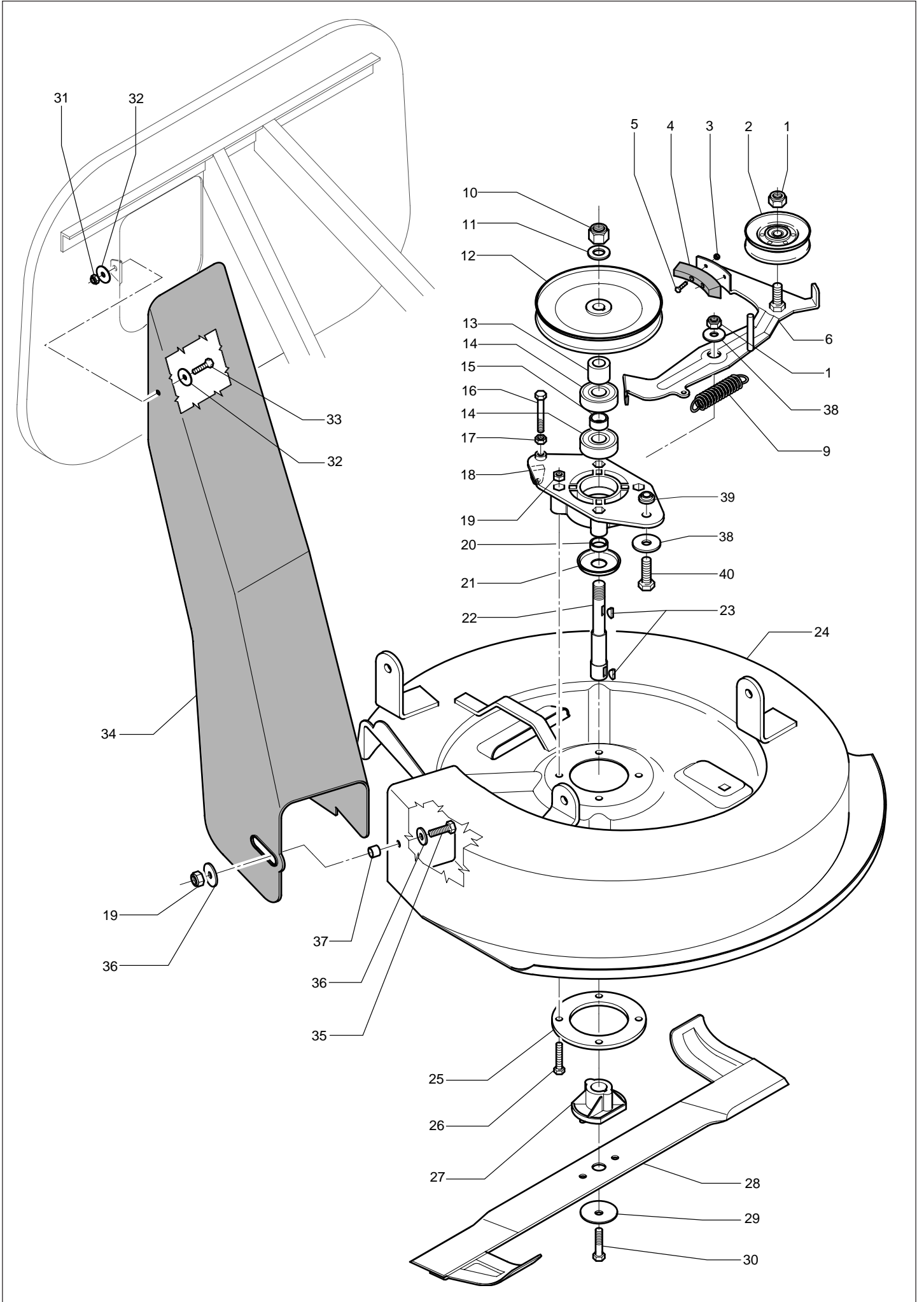

mod. 76 MEC - TAV. 3

KIT PIATTO - KIT PLATEAU - KIT PLATE - KIT TELLER - KIT PLATO - KIT BORD - KIT PRATO - KIT TALERZ - KIT TANYER - KIT DISK

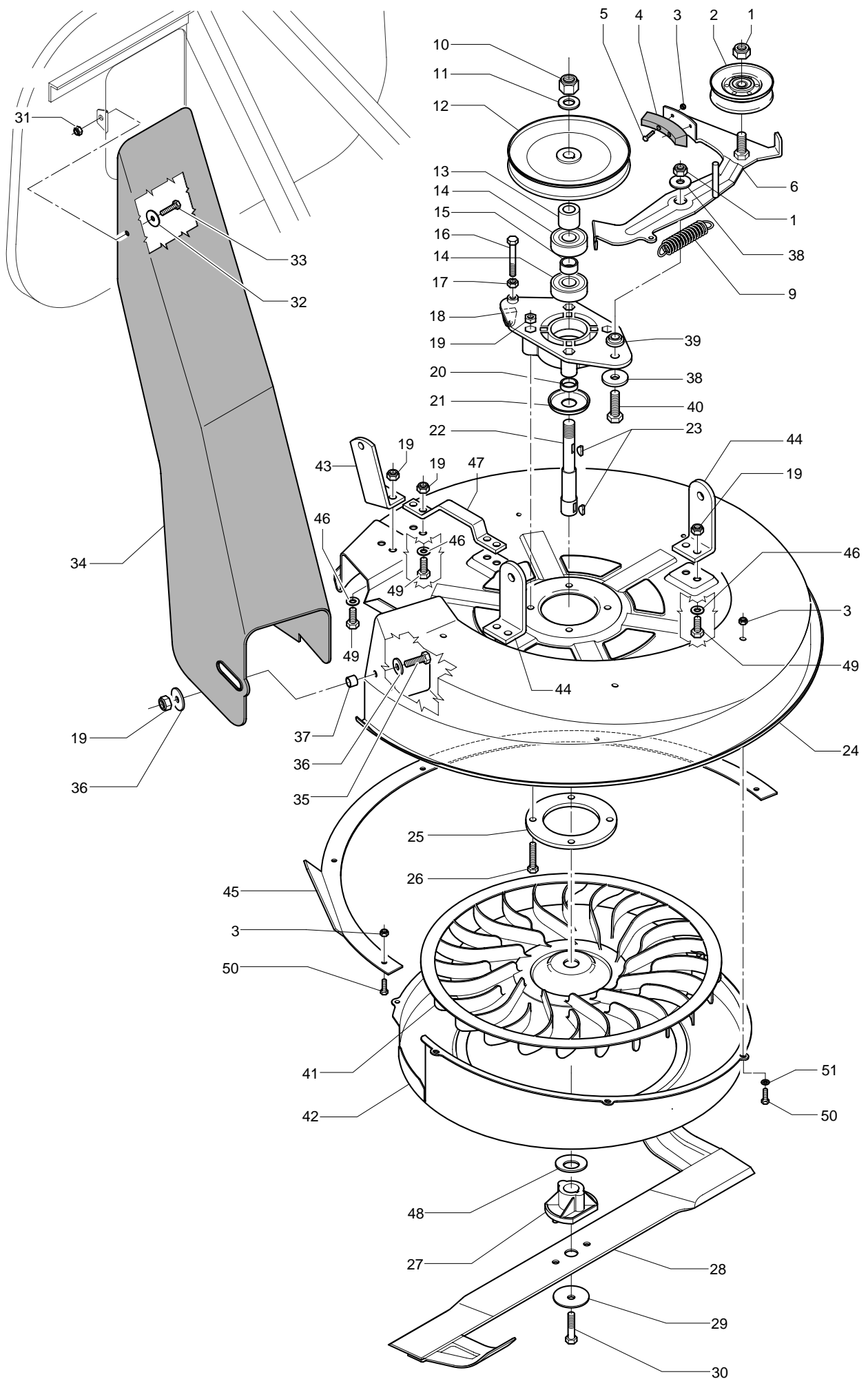

mod. 76 MEC - TAV. 3

KIT PIATTO - KIT PLATEAU - KIT PLATE - KIT TELLER - KIT PLATO - KIT BORD - KIT PRATO - KIT TALERZ - KIT TANYER - KIT DISK

N.ord. - N. pieces part. N. - Bestell N.	RICAMBI SPARE PARTS	RECHANGES ERSATZTEILE	RECAMBIOS ONDERDELEN	SOBRESSALENTES CZĘŚCI ZAMIENNE	CSEREALKATRÉSZEK NAHRADNÉ SÚCIÁSTKY	Q	
1 10 3015 60	dado autobloccante nut	ecrou Mutter	tuerca moer	porca nakrętką	anya matíca	2	M12-H.14 UNI 7473 Z.
2 10 3015 50	ruota tendicinghia belt-tightener wheel	roue tendeur courroie Riemenspannrad	nueda tensora de correa riemspanner-wiel	roda estender correia kolo naprężacza pasa	szíjfeszítőkerek napinací kolo remenu	1	
3 20 2821 00	dado autobloccante nut	ecrou Mutter	tuerca moer	porca nakrętką	anya matíca	13	M5-H.7 UNI 7473 Z.
4 10 3015 80	ferodo freno lama cutter brake ferodo	ferodo frein lame Messer-Bremsbelag	ferodo freno cuchilla ferodo mesrem	lona travão lamina ferodo hamulca ostrza	pengefék ferodo obložení brzdy nože	1	
5 10 8303 00	vite screw	vis Schraube	tornillo schroef	parafuso sruba	csavar skrutka	2	TE M5x16 UNI 5739 - 8,8 Z.
6 10 3015 10	leva tendicinghia lama cutter belt-tightener lever	levier tendeur courroie Riemenspannhobel	palanca tensora correa hendel riemspanner mes	alavanca estender correia dzwignia naprężacza pasa	pengeszíjfeszítőemeltető napinací páka nože	1	
9 10 3032 90	molla tendicinghia cutter-tightener spring	ressort tendeur courroie Riemenspannfeder	resorte tensor correa veer riemspanner	mola estender correia sprężyna naprężacza pasa	szíjfeszítőrugó pruzina napínáku remenu	1	
10 10 3014 90	dado autobloccante nut	ecrou Mutter	tuerca moer	porca nakrętką	anya matíca	1	M16 -H18 UNI 7473- Z.
11 10 3003 80	rosetta piana washer	rondelle Scheibe	arandela borgring	aniha podkładka	alátét podložka	1	Ø 17x30x2,5 - Z.
12 10 3014 70	puleggia pulley	poulie Riemenscheibe	polea poelie	polie kółko zamachowe	tárcsa remenica	1	Ø 178 - F.16
13 10 3014 60	distanziale spacer	entretoise Abstandsstück	separador afstandsring	distanciador dystans	közrögzőtő rozperka	1	Ø 17x30x25,5 H-Z.
14 10 3014 80	cuscinetto bearing	roulement Kugellager	rolamiento kugellager	rolamento łożysko	golyócsapágy łożysko	2	6304-2RS Ø 20x52x15
15 10 3013 60	distanziale interno internal spacer	entretoise intérieur Innen-Distanzstück	distanciador interior inwendig afstandstück	distanciador interior przekładka wewnętrzna	belső távolsító vnitřní rozperka	1	Ø 20x25x12,5 H
16 10 4076 00	vite screw	vis Schraube	tornillo schroef	parafuso sruba	csavar skrutka	1	TE M8x70 UNI 5737 - 8,8 Z.
17 20 1063 00	dado nut	ecrou Mutter	tuerca moer	porca nakrętką	anya matíca	1	M8 UNI 5587 Z.
18 10 3029 80	mozzo compl.sup.lama complete hub	moyeu complet Nebsatz	cubo completo complete naaf	cubo completo piastra kompletna	komplett kerékagy kompletní náboj	1	
19 20 4049 00	dado autobloccante nut	ecrou Mutter	tuerca moer	porca nakrętką	anya matíca	15	M8 - H.10 UNI 7473 Z.
20 10 3013 90	distanziale spacer	entretoise Abstandsstück	separador afstandsring	distanciador dystans	közrögzőtő rozperka	1	Ø 20x25x7 H
21 10 3014 10	parapolvere eccentrico eccentric hood	protège-poussière excentrique Ausmittiger Staubschutz	guardapolvo excéntrico excentrische stofbesch.	guarda-pó excêntrico ochrona przed pyłem	külponos porvédő kryt proti prachu	1	
22 10 3013 70	albero supporto lama blade support shaft	arbre support lame Messerwelle	eje soporte cuchilla as messupport	eixo suporte lamina wał podpora ostrza	pengertartótengely nosny kričel nože	1	
23 10 1009 00	linguetta tab	languette Lasche	lengueta lipje	lingueta wpust	nyelvecske klín	2	4x6,5 UNI 6606
24 10 3031 03	piatto completo complete plate	plateau complet Kompletter Teller	plato completo complete bord	prato completo talerz kompletny	komplett tányér kompletní disk	1	RIDER 76
25 10 3014 00	flangia di rinforzo reinforcement flange	bride de renfort Verstärkungsfiansch	brida de refuerzo versterkingsflens	flange de reforço kolmierz wzmacniający	erősítőkarima príruba zesílení	1	
26 10 0691 00	vite screw	vis Schraube	tornillo schroef	parafuso sruba	csavar skrutka	4	TE M8x45 UNI 5737 - 8,8 Z.
27 10 3014 20	supporto lama bearing blade	support lame Messerhalter	soporte cuchilla messemhouder	suporte da lamina uchwył noza	pergetaró drziak noża	1	
28 10 3030 50	lama blade	lame Messer	cuchilla mes	lamina nóz	penge nöz	1	cm.76 ALET TATA
29 10 5309 00	rondella elastica washer	rondelle Scheibe	arandela borgring	aniha podkładka	alátét podložka	1	Ø 11x50x2,5
30 20 1205 80	vite screw	vis Schraube	tornillo schroef	parafuso sruba	csavar skrutka	1	TE 3/8" UNFx37 - 8,8 Z.
31 20 2818 00	dado autobloccante nut	ecrou Mutter	tuerca moer	porca nakrętką	anya matíca	1	M6 - H8 UNI 7473 - Z.
32 10 8322 00	rosetta piana washer	rondelle Scheibe	arandela borgring	aniha podkładka	alátét podložka	1	Ø 6/24/2
33 20 1226 00	vite screw	vis Schraube	tornillo schroef	parafuso sruba	csavar skrutka	1	TE M6x20 UNI 5739 - 8,8 Z.
34 10 3016 53	tunnel carico erba grass loading tunnel	tunnel chargement herbe Grasladetunnel	túnel garga hierba Graslaadtunnel	túnel carga relva tunel ładowania trawy	fűrakodócső sberací tunel trávy	1	
35 10 1217 00	vite screw	vis Schraube	tornillo schroef	parafuso sruba	csavar skrutka	1	TE M8x35 UNI 5739 - 8,8 Z.
36 10 3016 70	rosetta piana washer	rondelle Scheibe	arandela borgring	aniha podkładka	alátét podložka	2	Ø 8x32x2,5 Z.
37 10 3016 00	distanziale spacer	entretoise Abstandsstück	separador afstandsring	distanciador dystans	közrögzőtő rozperka	1	Ø 10x14x16 H
38 10 3030 70	rosetta piana washer	rondelle Scheibe	arandela borgring	aniha podkładka	alátét podložka	2	Ø 12,5x36x2,5-Z
39 10 3030 60	boccola per tendicinghia bushing	douille Buchse	casquillo huls	casquillo tuleja	csapágycsésze poudzro	1	
40 10 3030 80	vite screw	vis Schraube	tornillo schroef	parafuso sruba	csavar skrutka	1	TE M12x35 - 8,8 UNI 5739 - Z.
41 10 3031 33	ventola piatto cooling fan	helice Lüfterrad	helice ventilator	helice kolo chłazące	ventilátor ventilátor	1	lama cm76
42 10 3031 13	coperchio ventola cover	couvercle Deckel	tapa kapje	tampa fedél	pokrywa veko	1	
43 10 3031 60	squadretta posteriore bottom bracket	support posterieur Hinternhalter	escuadra posterior houder	suporte uchwył	tartó drziak	1	
44 10 3031 70	squadretta anteriore prior bracket	support antérieur Früherhalter	esc uadra anterior houder	suporte uchwył	tartó drziak	2	
45 10 3032 43	deflettore deflector	deflecteur Prallblech	deflector deschermkap	deflector klapka	védőkarter chránic	1	
46 10 1142 00	rosetta piana washer	rondelle Scheibe	arandela borgring	aniha podkładka	alátét podložka	10	Ø 8/16/1,5Z
47 10 3032 63	staffa support	support Halter	soporte houder	suporte uchwył	tartó drziak	1	
48 10 3033 40	molla a tazza belleville washer	ressort á godet Becherfeder	muelle cónico compresión schotelveer	mola formato de taça sprężyna talerzowa	csésze formájú rugó talírová pruzina	1	DIN 2093 Ø 45/22,4/2,2
49 20 3823 00	vite screw	vis Schraube	tornillo schroef	parafuso sruba	csavar skrutka	10	TE M8x20 UNI 5739-8,8.Z
50 10 3033 00	vite screw	vis Schraube	tornillo schroef	parafuso sruba	csavar skrutka	11	TE M5x14 UNI 5739-8,8.Z
51 10 2847 00	rosetta piana washer	rondelle Scheibe	arandela borgring	aniha podkładka	alátét podložka	5	Ø 5/15/1,5 Z.

mod. 67 - mod. 76 MEC - TAV. 4

KIT TELAIO - KIT CHASSIS - CHASSIS KIT - KIT RAHMEN - KIT CHASIS - KIT FRAME - KIT CHASSI - KIT KORPUS - KIT VAZ - KIT KOSTRA

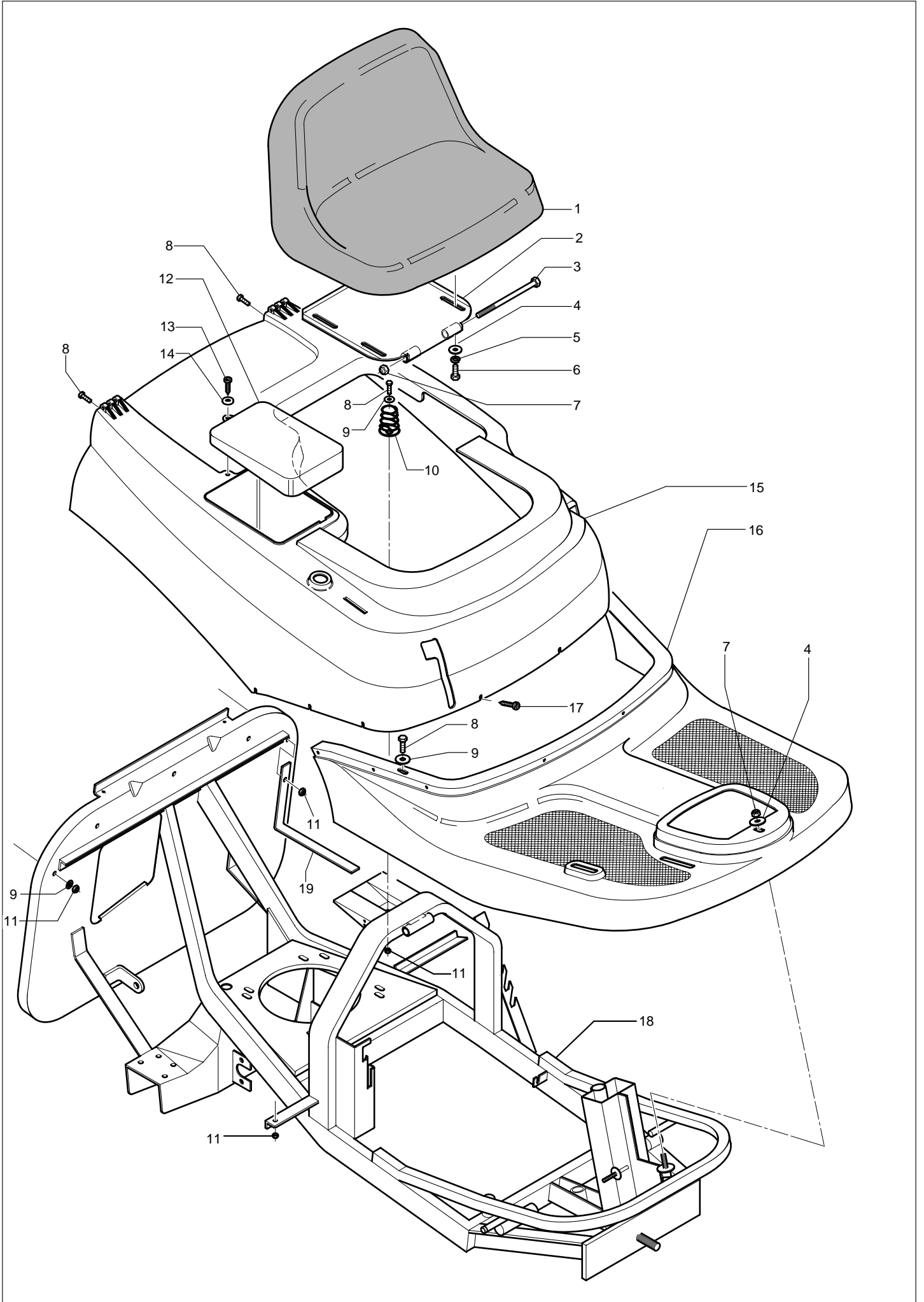

mod. 67 - mod. 76 MEC - TAV. 5

KIT STERZO - KIT ORG. DIRECTION - STEERING KIT - KIT STEUER - KIT DIRECCION - KIT STUUR - KIT DIRECÇÃO - KIT RAMIE - KIT KORMANY -
KIT VOLANTU

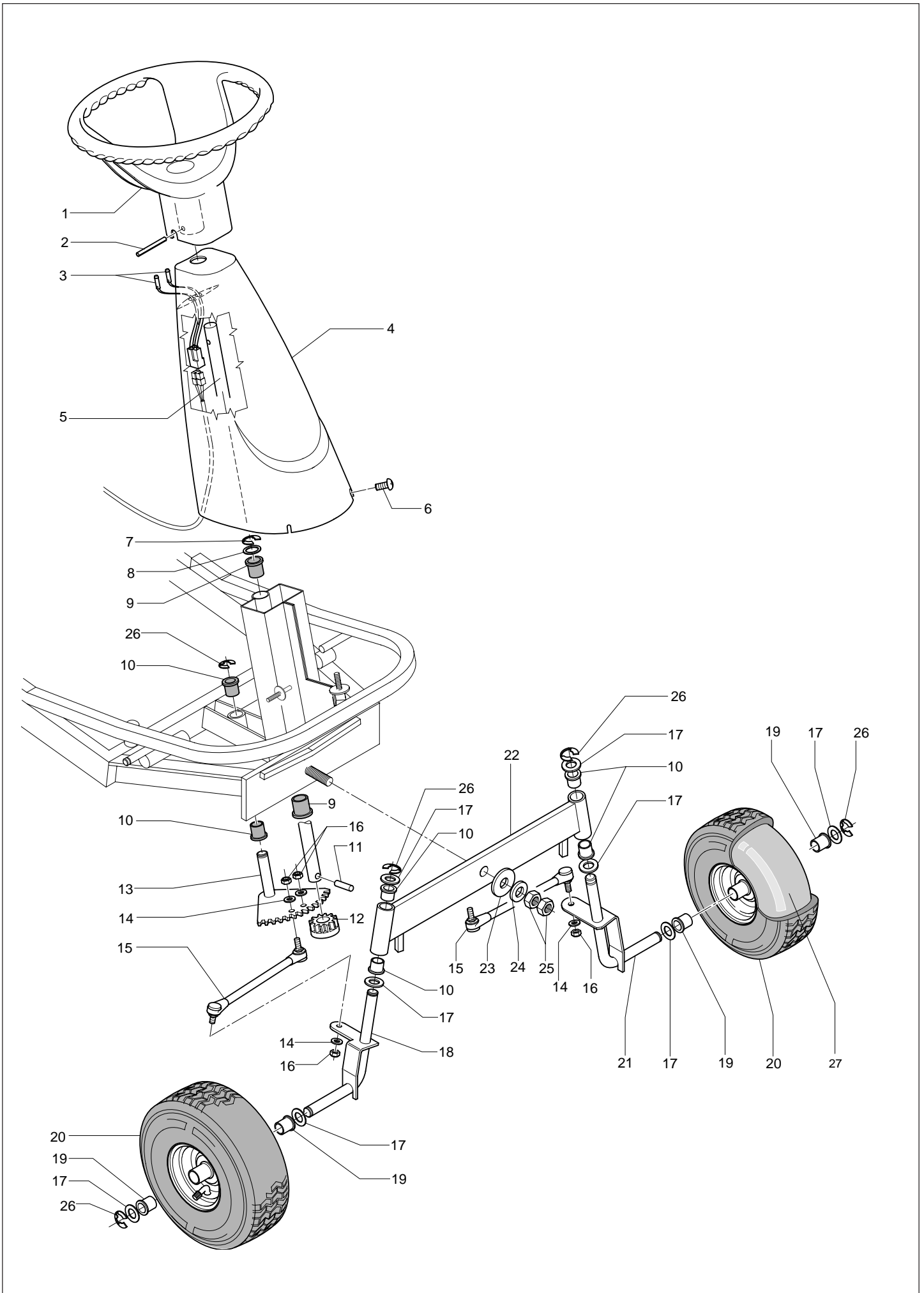

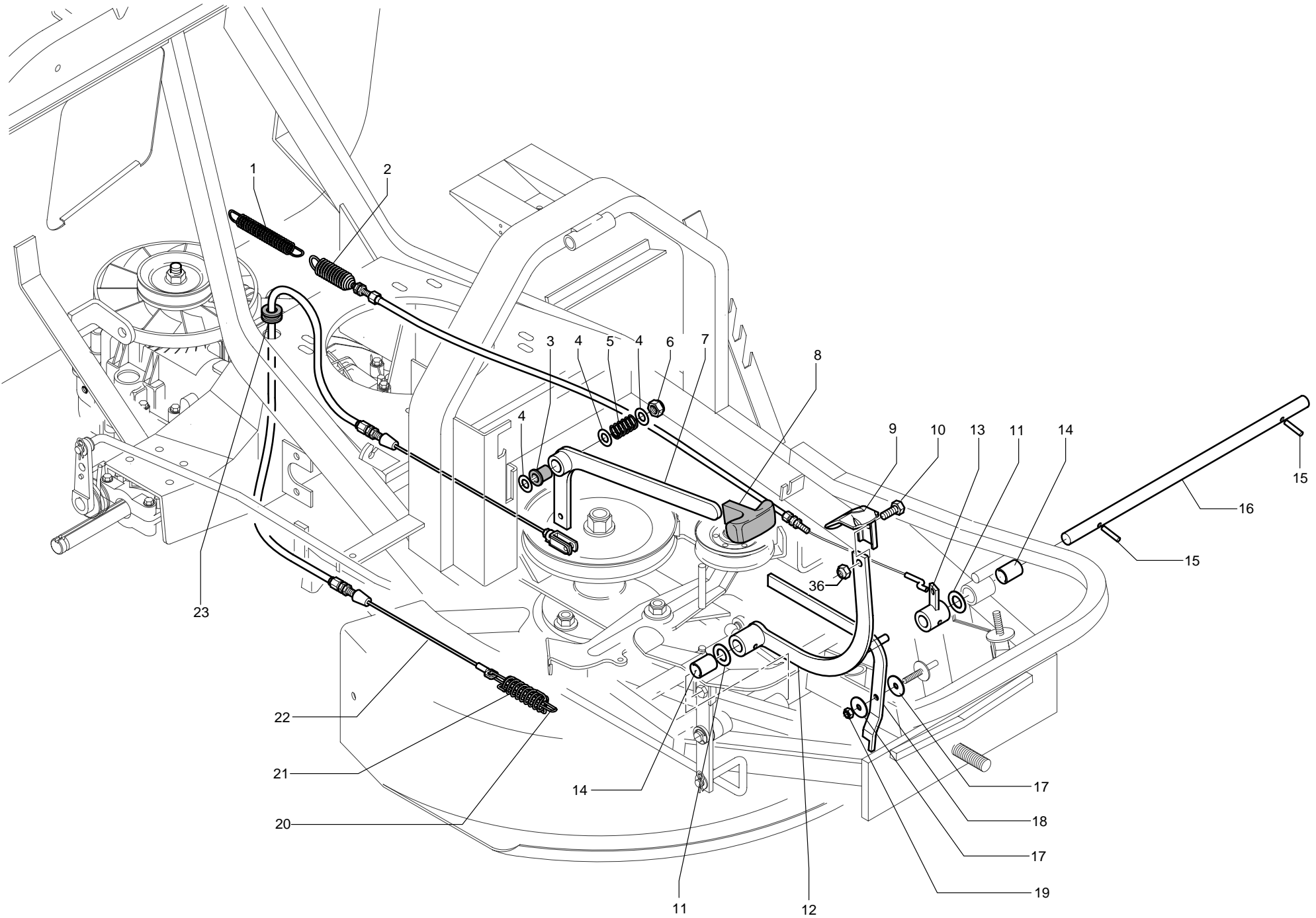

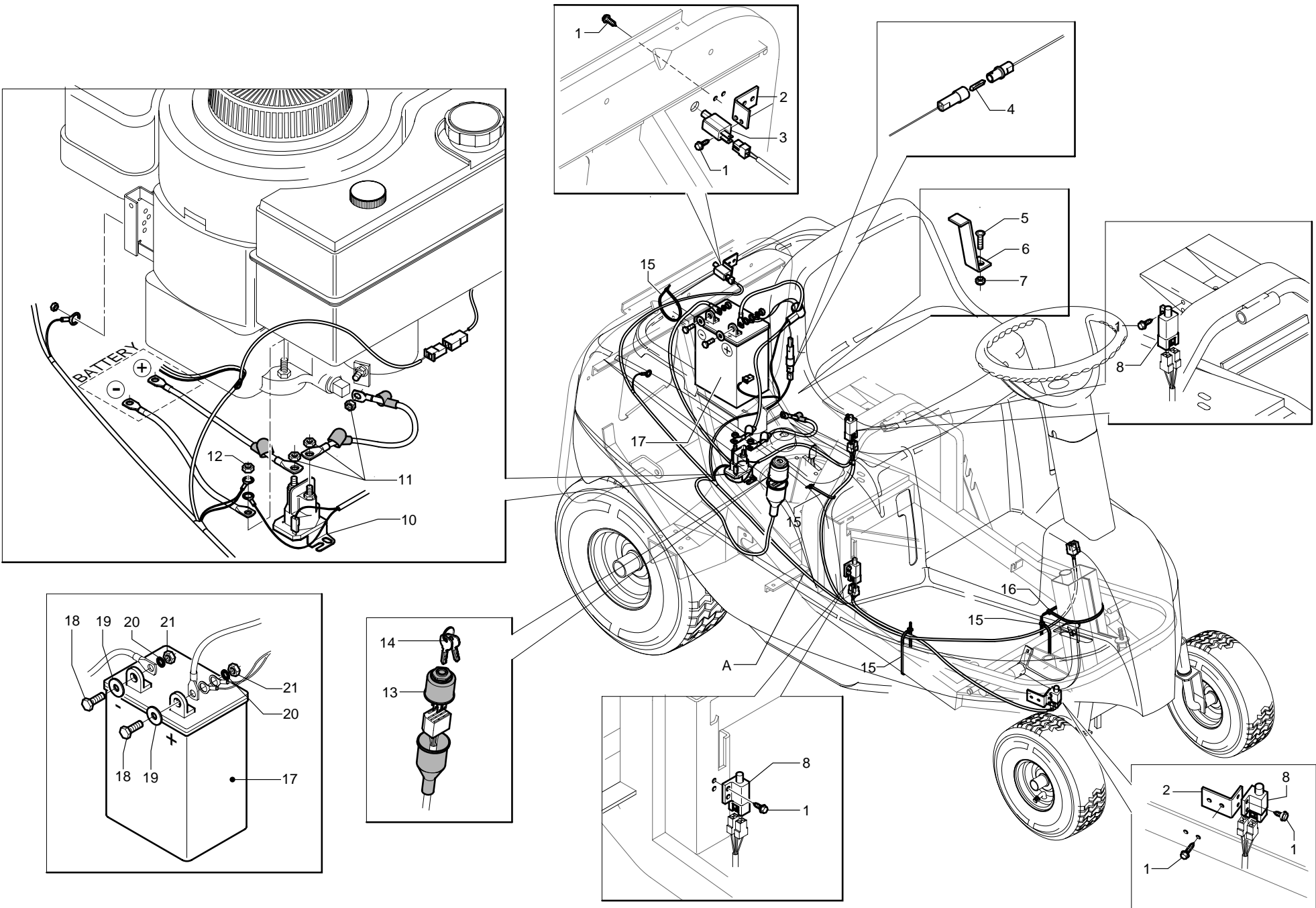

mod. 67 - mod. 76 MEC - TAV. 8

KIT RACCOGLIERBA - KIT BAC - GRASS CATCHER KIT - GRASFANGKORBES KIT - KIT CESTILLO - KIT GRASOPVANGBAK -
KIT CESTO - KIT ZBIORNIKA NA TRAWIE - FELSZERELESE KIT - ZBERACA SKOSENEJ TRAVY KIT

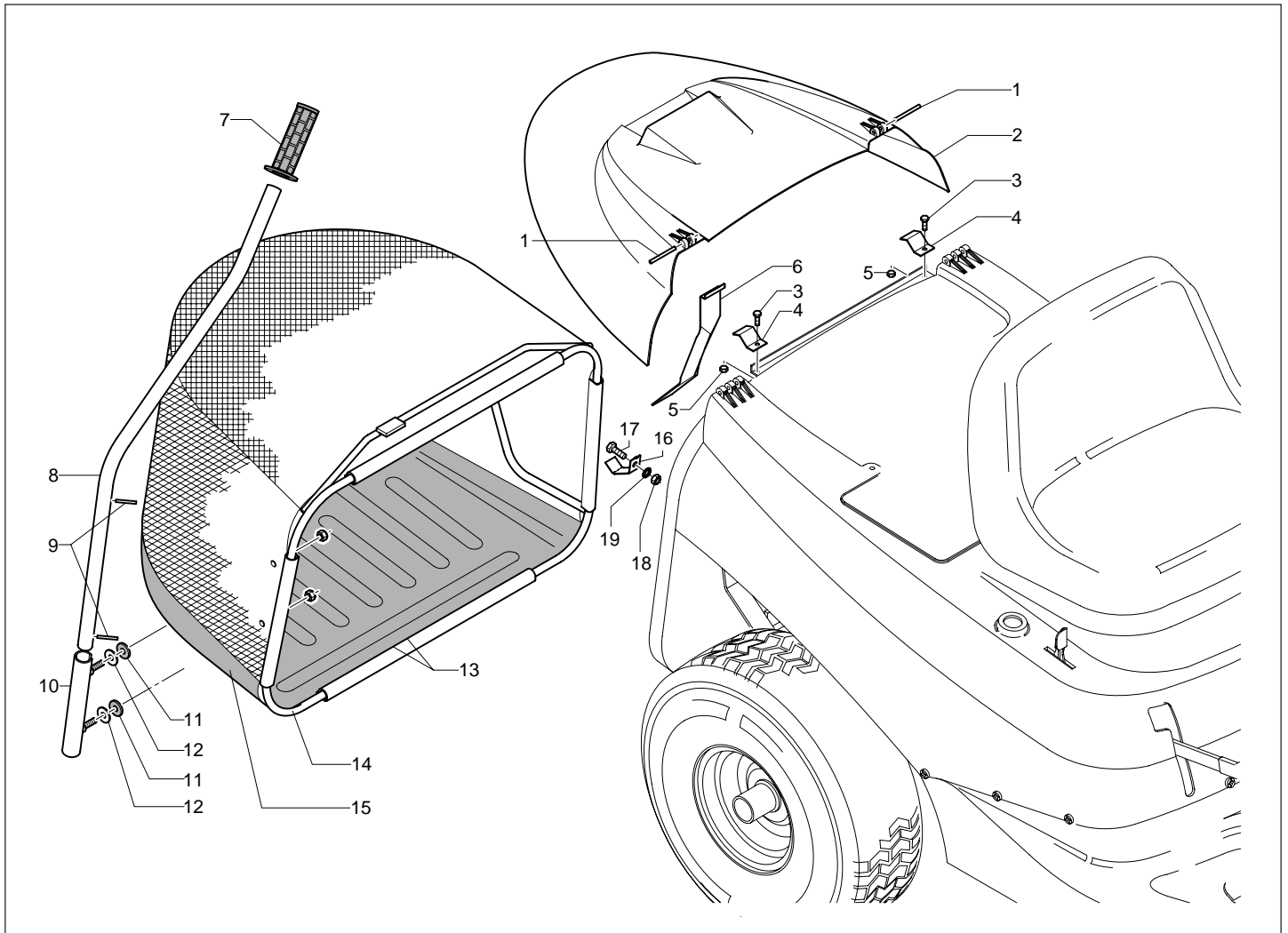

N.ord. - N. pieces part. N. - Bestell N.	RICAMBI SPARE PARTS	RECHANGES ERSATZTEILE	RECAMBIOS ONDERDELEN	SOBRESALENTES CZĘŚCI ZAMIENNE	CȘEREALKATRÉSZEK NÁHRADNÉ SUC*ASTKY	Q	
1 10 3027 40	spina cilindrica pin	goupille Spannhülse	pasador pin	golpilha napinacz	csap zastrčka	2	Ø 5x50 UNI 1707
2 10 3026 17	cop.cesto raccogliërba grass collector bin cover	couv.panier ramasseur Grasfangkorbdeckel	cob.cesto recogedor hierba bedekk.grasverzamelbak	tampa cesto colecta relva pokrycie kosza zbierania	fűgyűjtőkösárburkolat kryt sbërní kosík trávy	1	
3 20 6551 00	vite screw	vis Schraube	tornillo schroef	parafuso sruba	csavar skrutka	2	TE M6x16 UNI 5739 - 8,8 Z
4 10 3018 00	piastrina fissag.cesto bin fixture plate	platine fixation panier Graskorbblockierplättchen	placa fijación cesto bevestigingsplaatje bak	plaqinha fixação cesto plyta umocowania kosza	kosárrögztítő lernezeçske pripevnovací deska kosíku	2	
5 20 2818 00	dado autobloccante nut	ecrou Mutter	tuerca moer	porca nakrętkã	anya mãtica	2	M6 - H8 UNI 7473 Z.
6 10 3009 20	piastra rileva cesto pieno full bin monitor plate	plaque soulév.panier plein Graskorbfüll-Anzeigerpl.	placa detecta cesto lleno plaat voor waarneming	placa indic.cesto cheio plyta podnoszenia kosza	felikosár felmërõlemez signalizaçní deska kosík	1	
7 10 3017 93	manopola nera black knob	poignée noire Schwarzer Griff	manopla negra zwarte knop	botão preto uchwyt czarny	fekete húzókar cernã rukojet	1	Ø 20
8 10 3017 63	tubo ribaltamento cesto bin tilter tube	tube basculement panier Graskorbkipprohr	tubo basculamineto cesto slang bakomkanteling	tubo basculamento cesto rura wywracania kosza	kosárfelborítõcsõ vyklãpeçí trubka kosíku	1	
9 10 3017 70	spina Spirol pin	goupille Spannhülse	pasador pin	golpilha napinacz	csap zastrčka	2	Ø 4x26 DIN 7343
10 10 3017 43	supporto leva cesto bin lever support	support levier panier Graskorbhebelhalter	sop.palanca cesto supp.voor hendel bak	sup.alavança cesto podpora dzwigni kosza	kosáremeltyütartó držák páky kosíku	1	
11 10 3008 10	rosetta antivibrante washer	rondelle Scheibe	arandela borgring	aniha podklãdka	alãtét podlozka	2	Ø 9x25x3
12 10 0663 00	rosetta piana washer	rondelle Scheibe	arandela borgring	aniha podklãdka	alãtét podlozka	2	Ø 8x24x2 Z.
13 20 4049 00	dado autobloccante nut	ecrou Mutter	tuerca moer	porca nakrętkã	anya mãtica	2	M8 - H10 UNI 7473 - Z.
14 10 3017 13	intelaiatura cesto bin frame	cadre panier Graskorbrahmen	bastidor cesto bakframe	estrutura cesto szkielet kosza	kosárvãz nosní konstrukce kosíku	1	
15 10 3017 23	telatura cesto bin fabric covering	revêtement en toile panier Graskorbttuch	revestim.de tela cesto bakbedekking	forro do cesto konstrukcja kosza	kosár vászonburkolat plãténã vnitřní část kosíka	1	
16 10 3033 90	gancio cable hook	crochet Zugentlastung	soporte de cable haak	suporte do cabo uchwyt linki rozrusznika	horog hãk	1	
17 10 1182 00	vite screw	vis Schraube	tornillo schroef	parafuso sruba	csavar skrutka	1	M 8x12
18 20 1063 00	dado nut	ecrou Mutter	tuerca moer	porca nakrętkã	anya mãtica	1	M8
19 20 1062 00	rondella elastica washer	rondelle Scheibe	arandela borgring	aniha podklãdka	alãtét podlozka	1	Ø 8E

POS.	CODICE	I	F	D	GB	E	Q.TA'
1	CP019510	BATTERIA	ACCUMULATEUR	ACCU	BATTERY	ACUMULADOR	1
2	CP019515	CARICABATTERIA	CHARGEUR	AKKU-LADEGERÄT	CHARGER	CARGADOR	1
3	CP019520	CAVO ELETTRICO	CABLE	KABEL	CABLE	CABLE	1
4	CP019525	BLOCCHETTO AVVIAM	CONTACTEUR	ZÜNDSCHLOß	IGNITION LOCK	BLOQUE	1
5	CP030490	VITE TE	VIS	SCHRAUBE	SCREW	TORNILLO	2
6	CP044904	DADO	ÉCROU	MUTTER	KNOB	ESPARRAGO	2
7	CP032904	RONDELLA	RONDELLE	SCHEIBE	WASHER	ARANDELA	2

